

EL-36/6M Series

EL-36/6M120 (120 Watt)
EL-36/6M130 (130 Watt)
EL-36/6M140 (140 Watt)



CE ISO9001 IEC

Monocrystalline PV Modules

Everlight Monocrystalline photovoltaic panels offer industry leading performance in conversion efficiency and are designed specifically for our customers' residential, commercial and industrial needs.

Our high power modules are designed and manufactured to the highest standards, are built to last and backed by our solid product warranty. These modules are ideal for supplying energy for appliances in recreational vehicles and cabins, motor pumps, beacons, traffic signals, lighting equipment, fans and solar power recharging stations.

KEY FEATURES

Superior Performance

- Made with highly efficient, reliable Monocrystalline solar cells to ensure output stability and industry leading power generation.
- Low voltage temperature coefficient delivers higher power output
- Advanced surface texturing increases light absorption
- Each model is equipped with by-pass diodes to ensure performance even if partially shaded

Durability

- High-quality tempered glass, EVA and backsheet provide insulation and protection against the elements
- Our patented frame features anti-corrosion treatment and solid aluminum construction

Flexibility

- Our modules are stored and transported using custom packaging to ensure safe delivery
- Innovative hexagonal drainage holes increase flexibility and ease installation no matter what the application

Reliability

- 25 year limited warranty on power output
- 7 year limited warranty on materials and workmanship
- Manufactured to the highest standards in our ISO 9001:2008 certified plant, Helios Photovoltaic Co. Ltd.
- Certified by ISO, CE and IEC

Headquarters-Hong Kong

Everlight Corporation Ltd.
2506, West Tower, Shun Tak Centre, 168-200 Connaught Road, Central, Hong Kong
Tel: +852 6614 4916 Fax: +852 2815 1975
URL: www.everlight-solar.com



Manufactory-China

Helios Photovoltaic Co., Ltd.
Unit 3-A, 86 West Wujin Avenue, Wujin Hi-tech Industrial Zone 213164, Changzhou, Jiangsu Province, China
Tel: +86 519 8648 8901/2/3 Fax: +86 519 8648 2889
URL: www.helios-pv.com

EL-36/6M Series Technical Specifications

ELECTRICAL CHARACTERISTICS			
Model	EL-36/6M120	EL-36/6M130	EL-36/6M140
Maximum power (Pmax)	120W	130W	140W
Voltage at max. power (Vmp)	17.3V	18.2V	18.6V
Current at max. power (Imp)	7.01A	7.15A	7.47A
Open circuit voltage (Voc)	21.3V	21.8V	22.30V
Short circuit current (Isc)	7.70A	7.90A	8.12A
Temperature coefficient of Isc	(0.065 ± 0.015)%/°C		
Temperature coefficient of Voc	-(80 ± 10)mV/°C		
Temperature coefficient of power	-(0.45 ± 0.05)%/°C		
Operating temperature	-40/+85°C		
MECHANICAL CHARACTERISTICS			
Cell type	156 x 156 monocrystalline solar cell		
Cell array	36 pieces in a 9 x 4 matrix connected in series		
Dimensions (mm)	1482 x 676 X 35		
Weight (kg)	13.0		
Frame	Clear anodized aluminum alloy type universal frame; silver color		
Construction	Front: High-transmission 3.2 mm tempered glass Back: Polyester Encapsulant: EVA		

Module Diagram

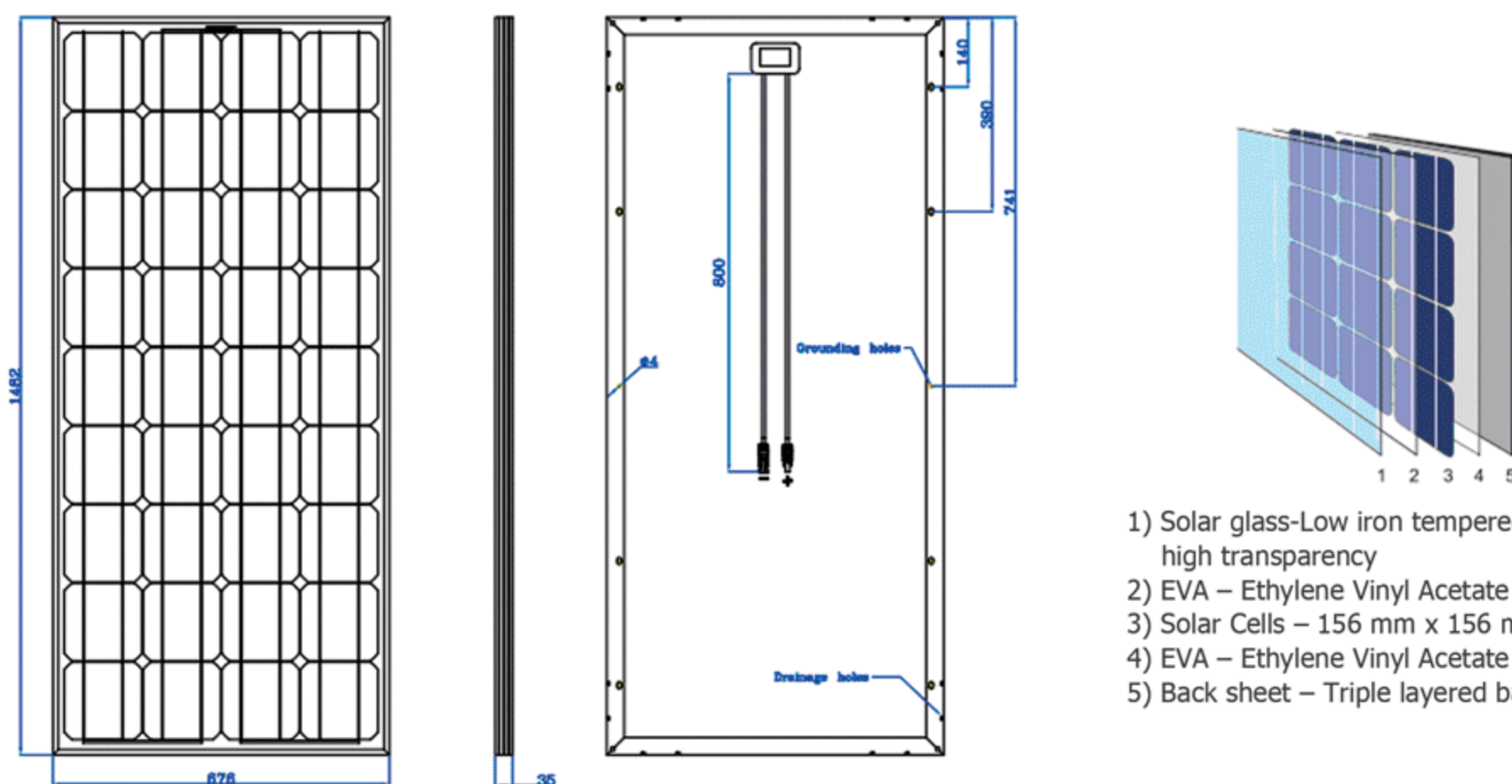

Electrical Performance

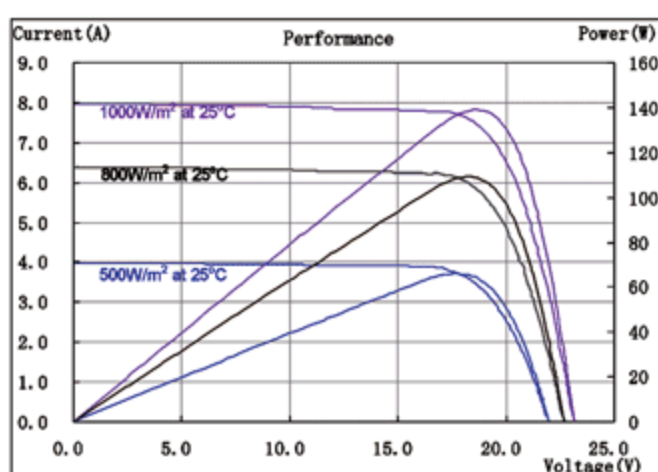

Power Output

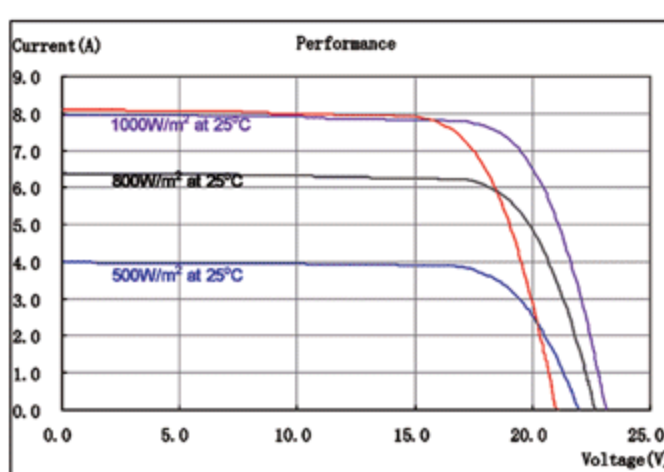

TEMPERATURE COEFFICIENTS

Isc = +0.065 %/°C
 Voc = -0.436 %/°C
 Pmax = +0.488 %/°C

Note: Due to continuous innovation, research and production improvement, design and specifications are subject to change without notice. No rights can be derived from this product information sheet and Everlight assumes no liability whatsoever connected to or resulting from the use of any information contained herein. Kindly contact Everlight to obtain the latest product manuals before using.