



80 Watt Photovoltaic Module

EVERLIGHT ELM-80P Series

EVERLIGHT ELM-80P photovoltaic modules offer industry-leading performance, durability, and reliability for electrical power requirements. An anti-reflective coating provides a uniform blue color and increases the absorption of light in all weather conditions. Common applications include RVs, cabins, solar power stations, pumps, beacons, and lighting equipment. Designed to withstand rigorous weather conditions, a junction box is also provided for easy electrical connections in the field, making EVERLIGHT modules the perfect combination advanced technology and reliability.

TYPICAL ELECTRICAL CHARACTERISTICS			
	ELM-80P-1	ELM-80P-2	ELM-80P-3
Maximum power	75W	80W	85W
Voltage at max. power	17.5 V	17.5 V	17.5 V
Current at max. power	4.29A	4.57A	4.86A
Open circuit voltage	21.7V	21.7V	21.7V
Short circuit current	4.94A	5.27A	5.60A
Temperature coefficient of Isc	(0.065±0.015)%/°C		
Temperature coefficient of Voc	-(160±20)mV/°C		
Temperature coefficient of power	-(0.5±0.05)%/°C		
Max. oper. voltage	1000V		
Operating temperature	-40/+85 °C		
Resistance	227g steel ball down from 1m height and 60m/s wind		

PERFORMANCE			
Model	ELM-80P-1	ELM-80P-2	ELM-80P-3
Rated power	75W	80W	85W
Tolerance	±5%	±5%	±5%
Module efficiency	14.0%	15.0%	15.9%
Nominal voltage	12V	12V	12V
Warranty	Pm is not less than 90% in 10 years and 80% in 25 years		

MECHANICAL CHARACTERISTICS	
Dimensions(mm)	1200×540×40
Overall tolerances	±3mm
Weight(Kg)	7.5
Frame	Clear anodized aluminum alloy type 6063T6. Silver Universal frame.
Solar Cells	36 cells (125 x 125mm) configured geometrically in a 9 x 4 matrix connected in series.

Test conditions: @STC 1000W/m², AM1.5, 25°C

Product Standards: CE certified, TÜV according to IEC 61215 expected by Oct. 2007.

Module Diagram

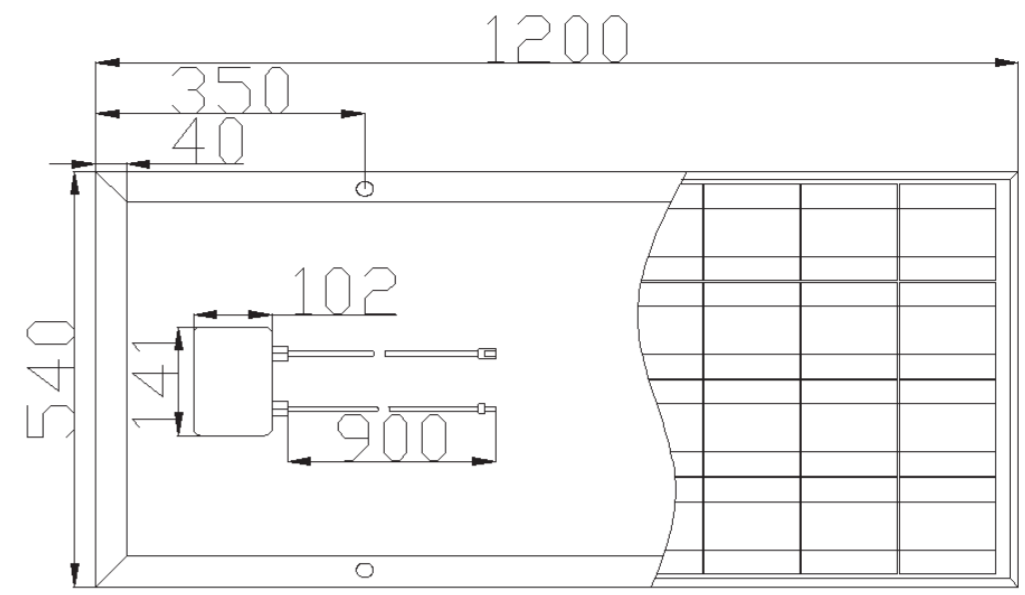

Graph

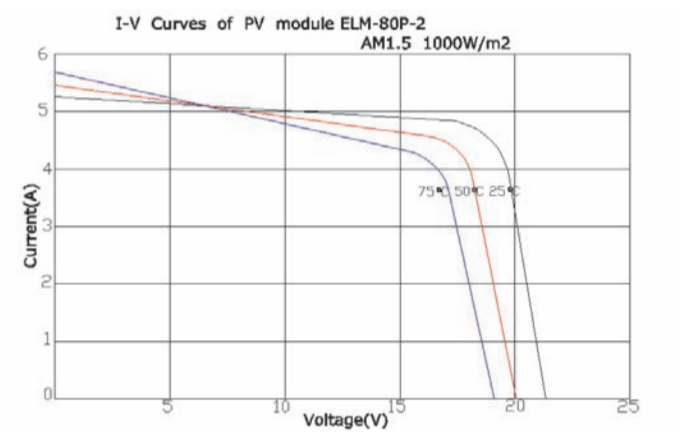
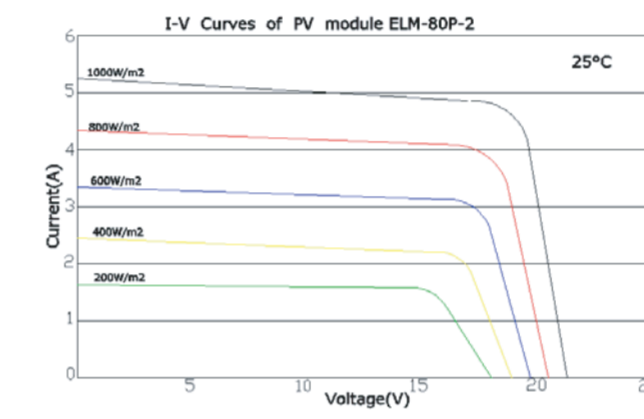
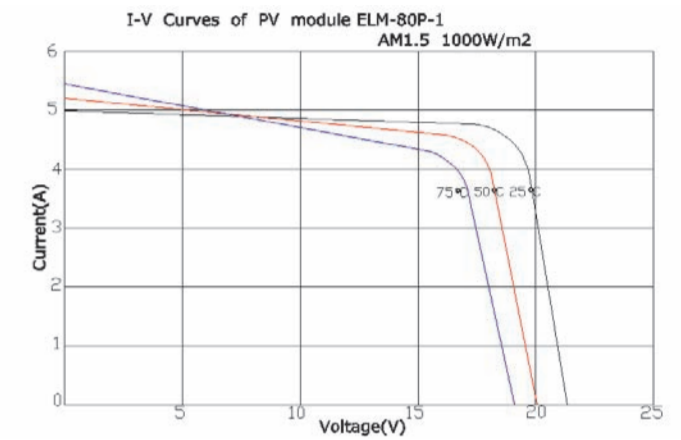
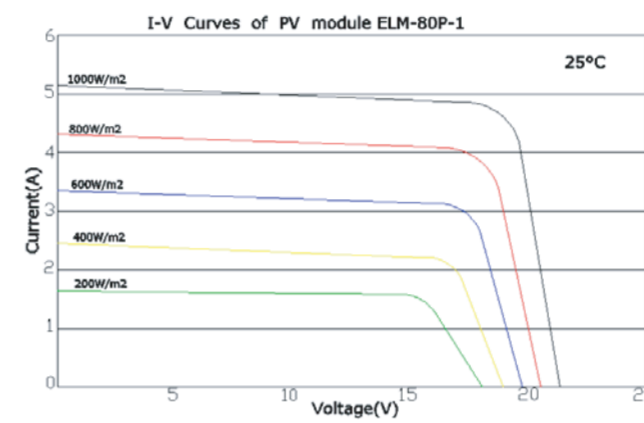

www.everlight-solar.com

www.everlight-solar.com

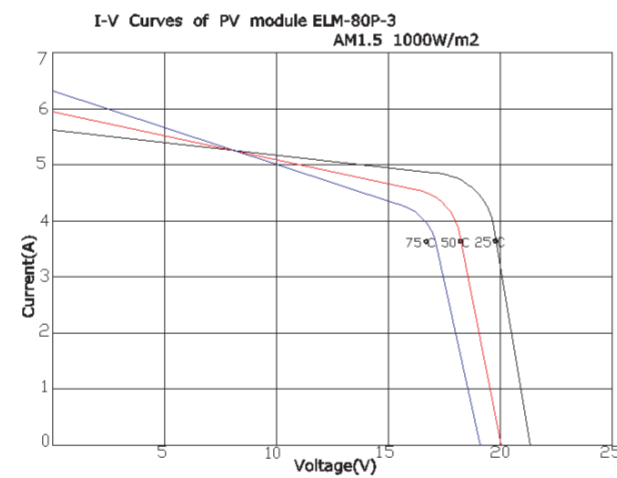
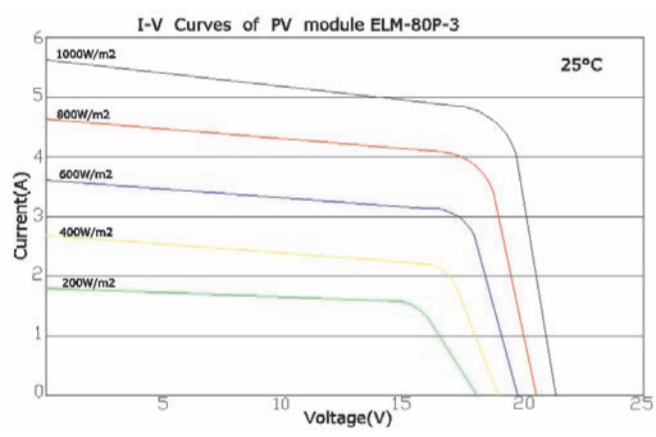

www.everlight-solar.com

www.everlight-solar.com